

3 - DEEP PUSHBACK

FEATURES AND BENEFITS:

- PUSHBACK HAS THE LOWEST PROFILE HEIGHT ON THE MARKET.
- HEAVY DUTY STRUCTURAL STEEL CONSTRUCTION WITH SUPERIOR IMPACT RESISTANCE IS BUILT TO HANDLE 3,000 LB LOADS.
- CARTS HAVE INTEGRATED CRITICAL SAFETY FEATURES: LIFT-OUT PROTECTION, LINKED CARTS, AND SAFETY STOPS.
- STRUCTURAL TUBE RAILS OFFER A SMOOTH ROLLING SURFACE AND ONLY REQUIRE ATTACHMENT AT FRONT & REAR, NO ATTACHMENT TO INTERNAL BEAMS IS REQUIRED.
- MACHINED STEEL WHEELS WITH PRECISION BEARINGS ON WELDED STEEL SHAFTS - NO BOLTED WHEELS.
- CARTS COME FULLY ASSEMBLED - NO NEED TO INSTALL WHEELS.
- EASY TRANSPORTATION, EASY INSTALLATION AND EASY TO USE.
- DURABLE POWDER COATED FINISH, AVAILABLE IN GREY, BLUE OR GREEN.
- CUSTOM COLOURS OR HOT DIP GALVANISED FINISH AVAILABLE UPON REQUEST.

3 DEEP LOW PROFILE STEADIFLO PUSHBACK
(for a typical 40" wide x 48" deep GMA/CHEP style pallet)
PART NO. PB34048-STN

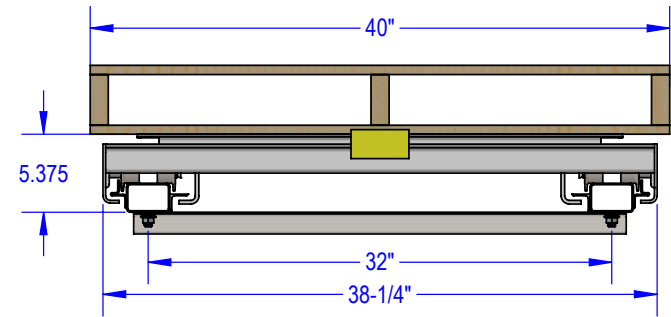

PROFILE

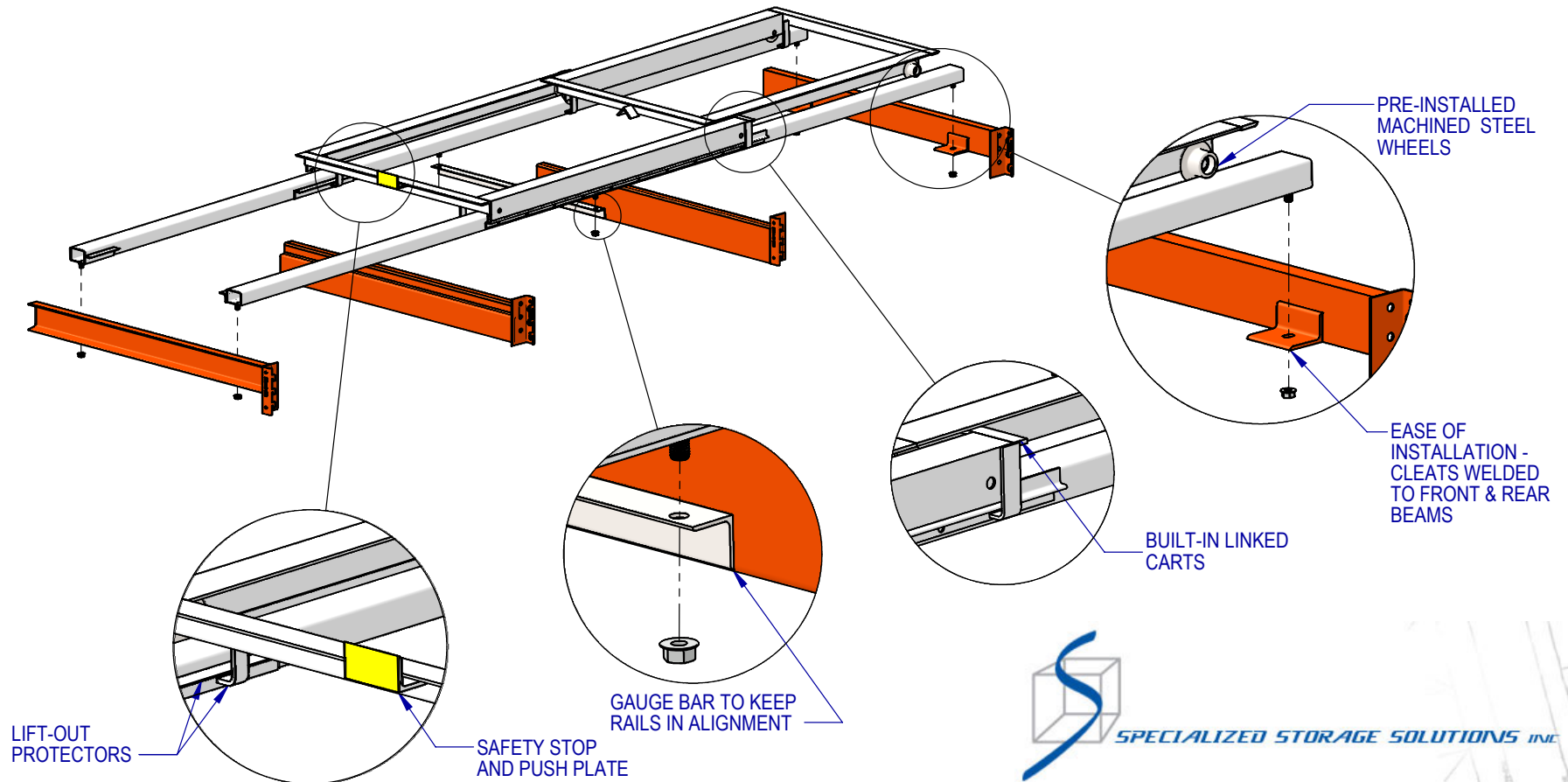

ITEM NO.	PART NUMBER	DESCRIPTION	QTY.
1	PB34646ST-AUS	3 DEEP TOP CART	1
2	PB34646SB-AUS	3 DEEP BOTTOM CART	1
3	PB34048R-STN	RAILS, 3 DEEP, L.H.S. & R.H.S	1
4	PB40GB-ST	PUSHBACK GAUGE BAR	1
5	-	#1/2"-13 X 0.5 FLANGE NUT, ZP	6

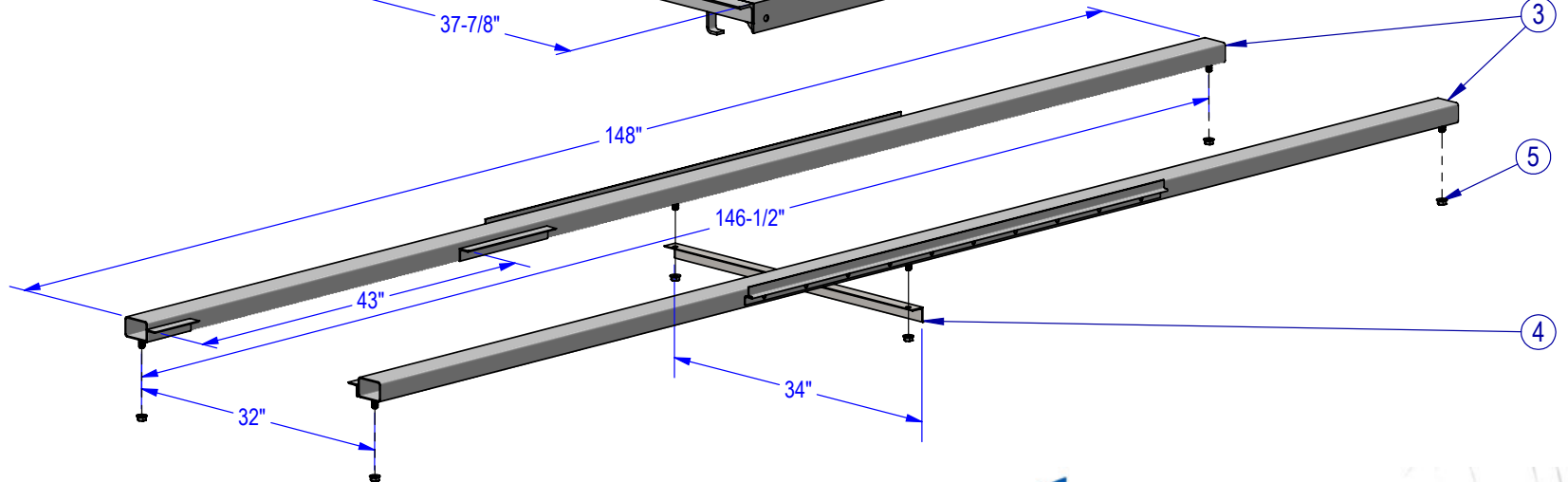
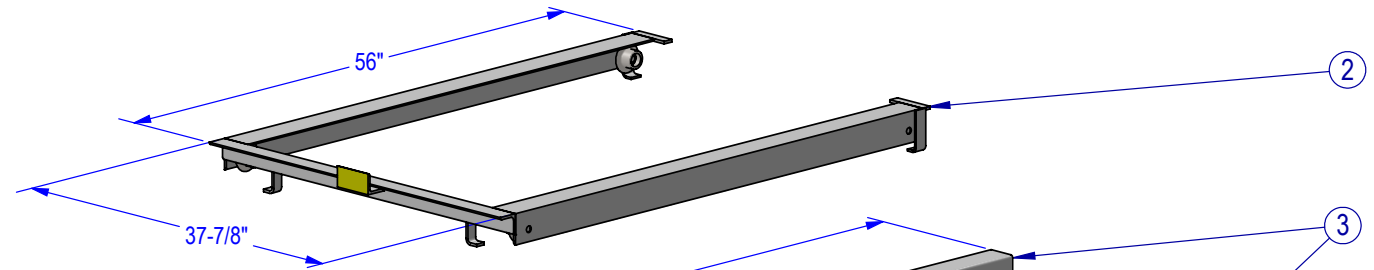
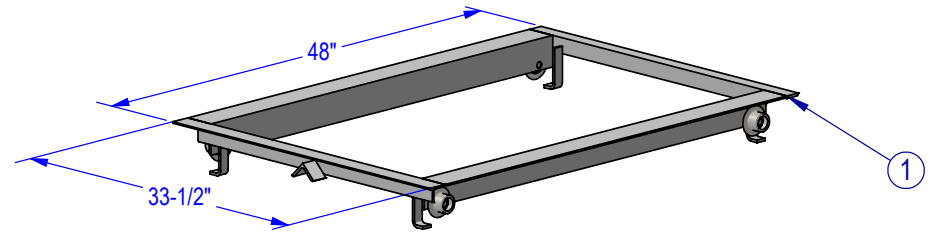

COMPONENT DIMENSIONS FOR STANDARD 3 DEEP PUSHBACK LANE.



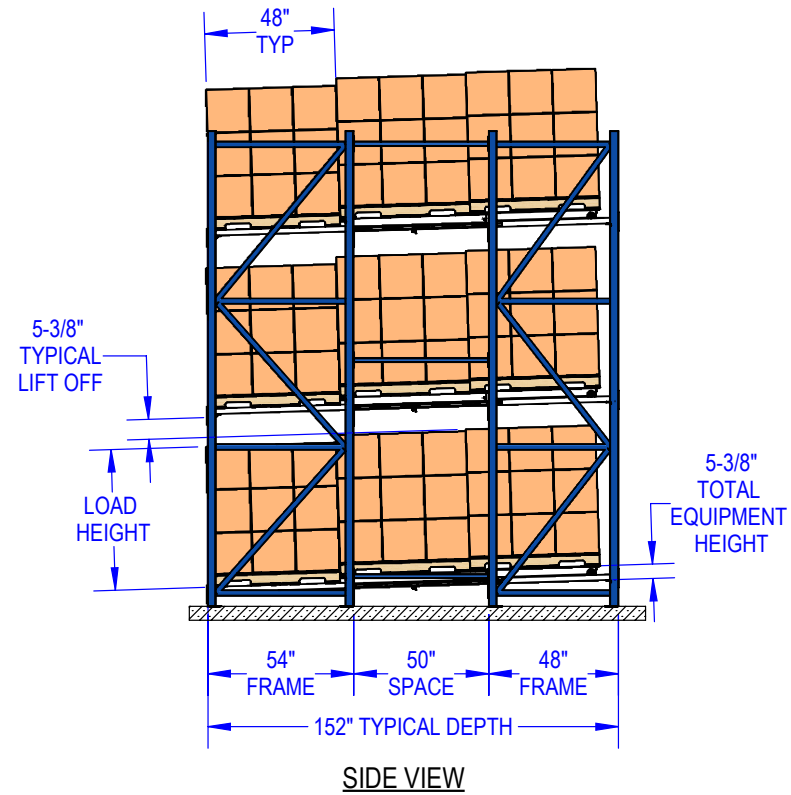
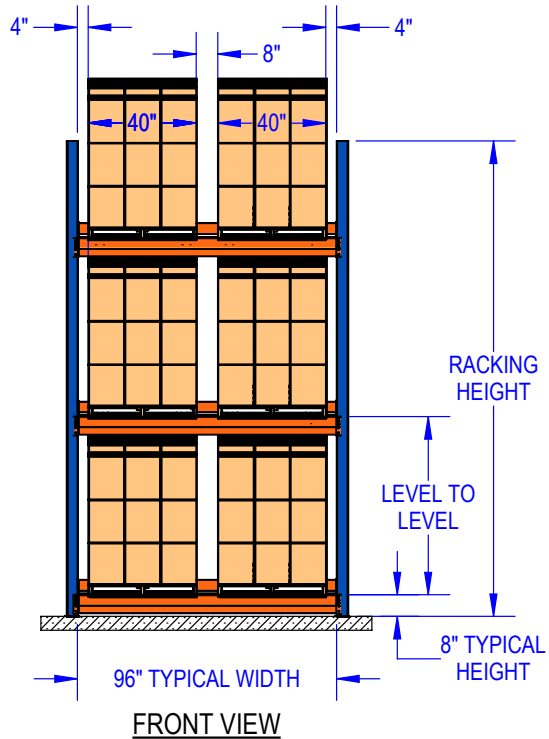

TYPICAL DOUBLE WIDE 3-LEVEL HIGH BAY OF 3 DEEP PUSHBACK LANES FOR STANDARD 40" WIDE X 48" DEEP GMA/CHEP STYLE PALLET:

- LEVEL TO LEVEL DISTANCE = LOAD HEIGHT + INTERNAL BEAM HEIGHT + 5-3/8" + 1"
- RECOMMENDED RACKING HEIGHT = FRONT BEAM HEIGHT + LEVEL TO LEVEL DISTANCE x NUMBER OF LEVELS + LOAD HEIGHT / 2
- RECOMMENDED SLOPE = 3/8" DROP PER FOOT.
- CENTER TO CENTER DISTANCE FOR RAIL STUDS: 32" SIDE TO SIDE & 146-1/2" FRONT TO BACK.



PUSHBACK INSTALLATION GUIDE

3 - DEEP PUSHBACK SYSTEM

3D Pushback Systems are designed to be installed quickly, easily and without field measurement or adjustment. Standard rails have threaded studs welded on the bottom of the rail tube at each end. Front and rear beams, supplied by the rack manufacturer, are normally channel beam construction and include structural angle cleats with slots for mounting the rails. Alternatively, front and rear beams may be of structural angle construction with slots punched to exact spacing to ensure that rails are appropriately spaced and parallel.

Beams in the rack should be installed so that the rail slopes upward from the front beam (at the aisle) to the rear beam. Designers at the rack manufacturer determine the bracket drops on beams to achieve the appropriate slope, which is normally 3/8" per foot.

Typically the rails are fastened only at the front and rear beam positions. 3D has 2 methods of fastening the rails to the beams.

1. STUD MOUNT

This style of rail attaches with 1/2" threaded studs welded to the bottom of each end of the rail. Slots in the beam should line with these studs and a 1/2" flange nut should be fastened to the stud once in place. Keep in mind that the rails must be oriented with the lift out angle to the front and facing the inside of the lane.

2. PLATE MOUNT

This style of rail differs only slightly from the rail above. The front and rear of the rail tube should have plates with 1/2" holes. These should match up to the holes punched in the front and

rear beam. These are then secured with a 1 1/2" x 1/2" bolt and a 1/2" flange nut or nyloc nut.

Each three deep nested style lane consists of two rails and two carts. The two rails in any lane are different from each other (one left hand, plus one right hand). Each rail has an (lift-out protector) angle 1 1/4" x 1 1/4" x approximately 6" long at the front and 12" long in the middle. Rails should be installed so that the end with the angle is at the load/unload end. Right-hand and left-hand rails vary in that the lift-out protector angles each face the middle of the lane. When the cart is installed, the lift-out angle brackets on the cart will fit under the angles on the rails.

The hardware required to fasten the rails to the beams is supplied by 3D Storage.

The carts are installed by placing them on the rails just past the lift out angle at the front of the lane. Start with the bottom cart and then repeat this step to install the top cart. The bottom cart has a push plate (4" wide, protruding 3/4" above the cart) in the center of the front cross member. The carts are always installed with the push plate and or the cross tie closest to the load/unload end.

After the carts are installed, they should be checked to ensure that they roll freely up and down the lane. When pushed up a lane, a cart should return to the load/unload end when released. If not, check to ensure that the small lift-out brackets on the cart are running freely below the 1 1/4" x 1 1/4" angle on the inside of each one of the rails.

PUSHBACK INSTALLATION GUIDE

3 - DEEP PUSHBACK SYSTEM

Carts should have a small amount of side shift allowance to prevent binding of the wheels against the rail. This side shift allowance should be approximately 5/16". If side shift is significantly different from this dimension, then it is advisable that the installer measures the exact distance between the rails and then contacts the rack manufacturer who made the beams or 3D Storage to isolate the cause.

At times it is necessary to floor mount a lane, this is done by replacing beams with risers. The front beam is replaced by a structural angle that is anchored to the floor, the rails attach to it by means of a plate mount. The second position risers are welded to the rails at the time of manufacture. The third position risers are placed on the floor underneath the rails and then slid forward to the front of the system to where the rails are just touching the risers. These risers are then anchored to the floor using the anchors supplied by the rack manufacturer. The rear beam is a rack-mounted beam, the same as the rear beams on the upper levels.

When installed flanged wheels should always sit inside the Z guide, not outside of it.



CORRECT



INCORRECT



LOAD
UNLOAD
END

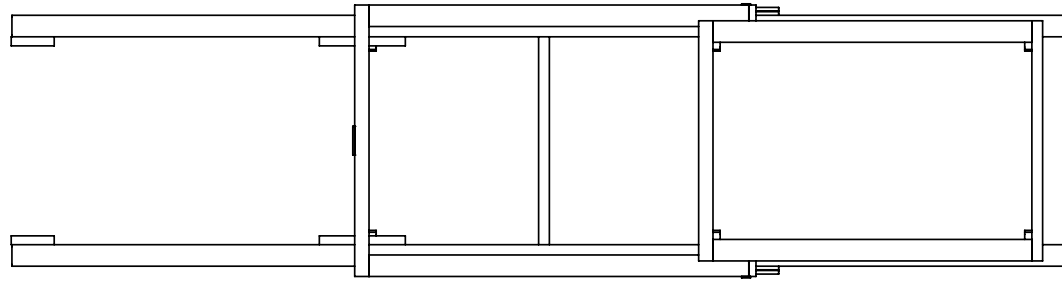

3 DEEP LANE - EXTENDED - TOP VIEW

LOAD
UNLOAD
END

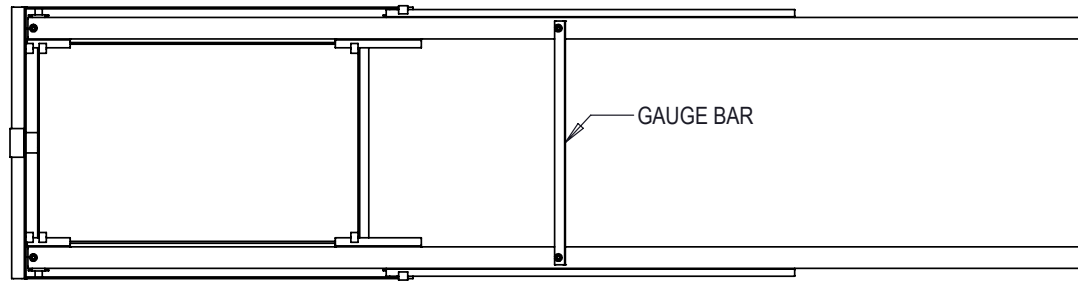

3 DEEP LANE - EMPTY - BOTTOM VIEW

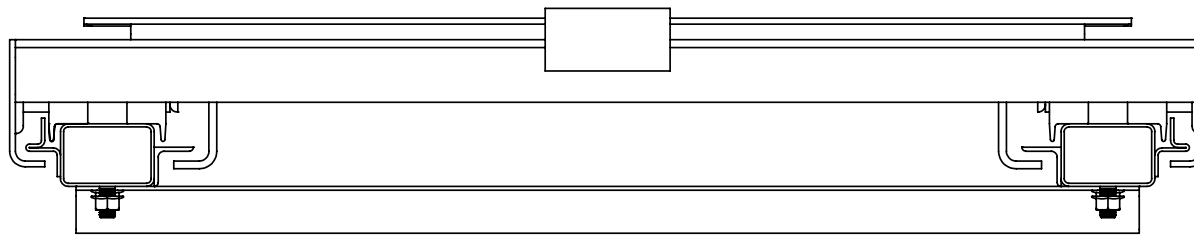

FRONT VIEW

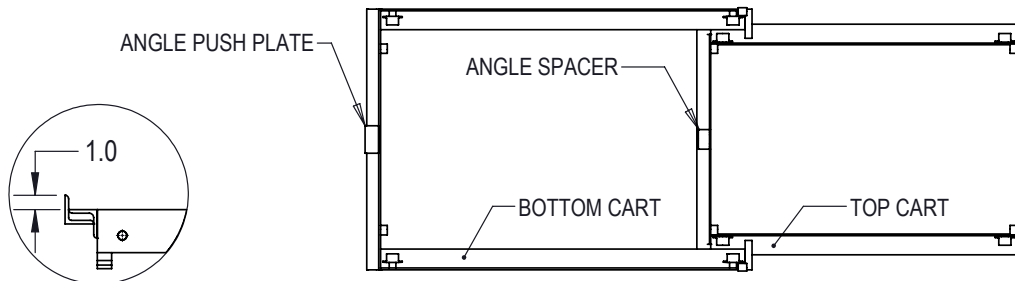

3 DEEP PUSHBACK LANE - CARTS ONLY - BOTTOM VIEW

OPERATING INSTRUCTIONS

3 - DEEP PUSHBACK SYSTEM

1. Pallets must be loaded and unloaded with the forklift squared up to the face of the rack – **Do not approach or withdraw at an angle.**
2. When loading the first pallet, make sure the pallet is slightly tilted back towards the truck and 1 to 2 inches above the push plate. If the pallet catches the plate or any cart when loading, lift the pallet a few inches and allow the cart to return to the front before proceeding.
3. Put the first pallet down on the cart, ensuring that the pallet is flush with the front of the cart, and not resting on top of the push plate.
4. When loading the second pallet, enter while pushing on the first pallet loaded with the back of the pallet being loaded. Push the pallet all the way in and place it on the waiting cart, continue to do this until you are loading the final pallet in the system. Here you are going to enter low enough to catch the Push plate with the pallet being loaded, push the pallet all the way in and place it on the rails behind the front beam. Always push back at a slow and constant speed.
5. When removing pallets from the lane, lift the pallet to a level position just high enough to clear the push plate or the front beam. **Withdraw at a slow and constant speed.**
6. Make sure that the following pallet comes to the front of the system. If for some reason the pallet is stuck and does not roll forward during unloading, push the pallet back in and back out again. If the pallet is still stuck, reload the lane and do not unload until the cause of the jam has been found and removed. **Do not leave stuck pallets in the back of a lane without a loaded pallet in front of it.**